



DATA SHEET

TG-1000 POWER BRAVA

BRAVA SERIES

ELECTRIC EQUIPMENT



Aluminium



Electric



300 Kg unassisted



- ▷ Control the stretcher from the operator's position.
- ▷ Control panel intuitive, autonomous and functional.
- ▷ Adjustable headrest with shock absorber.
- ▷ Double-jointed leg rest with 2 shock absorbers.
- ▷ 4 ø160 mm rotating wheels.
(2 remote-lockable wheels via pedal).
- ▷ Laterally and longitudinally collapsible guardrails.
- ▷ Three-point safety belt kit and IV pole.
- ▷ Aluminium tray for performing cardiac massages.
- ▷ The head area features a telescopic frame to facilitate manoeuvring in places with difficult access.
- ▷ Hydraulic system unlocking button in case of fault.

PRODUCT SPECIFICATIONS

		TG-1000
H	Max. height (mm)	1300
HC	Max. adjustable height (mm)	1030
H2	Min. height (mm)	350
L	Length (mm)	1972
L2	Length closed (mm)	1610
L3	Length open (mm)	2100
W	Width (mm)	574
	Load capacity (kg)	300
	Weight (kg)	74

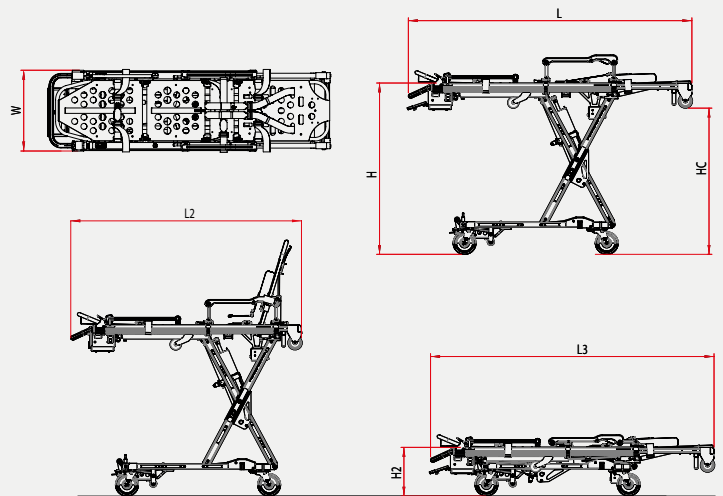

RELATED PRODUCTS



R-1002A BRAVO



R-1001 BRAVO



R-1001C BRAVO



TG-1000 IN



Bariatric Kit



KARTSANA

Life-moving innovation

Narcís Monturiol, 34
08192 · Sant Quirze del Vallès
Barcelona (Spain)

T.: +34 93 715 86 72
info@kartsana.com
www.kartsana.com

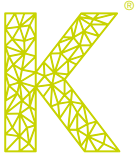

DATA SHEET

R-1001 / R-1002A / R-1002C BRAVO

BRAVA SERIES

ELECTRIC EQUIPMENT



Aluminium and steel



Lateral movement
*R-1002A,
R-1002C



Backboard stretcher drawer
*R-1002C



CERTIFIED 10G

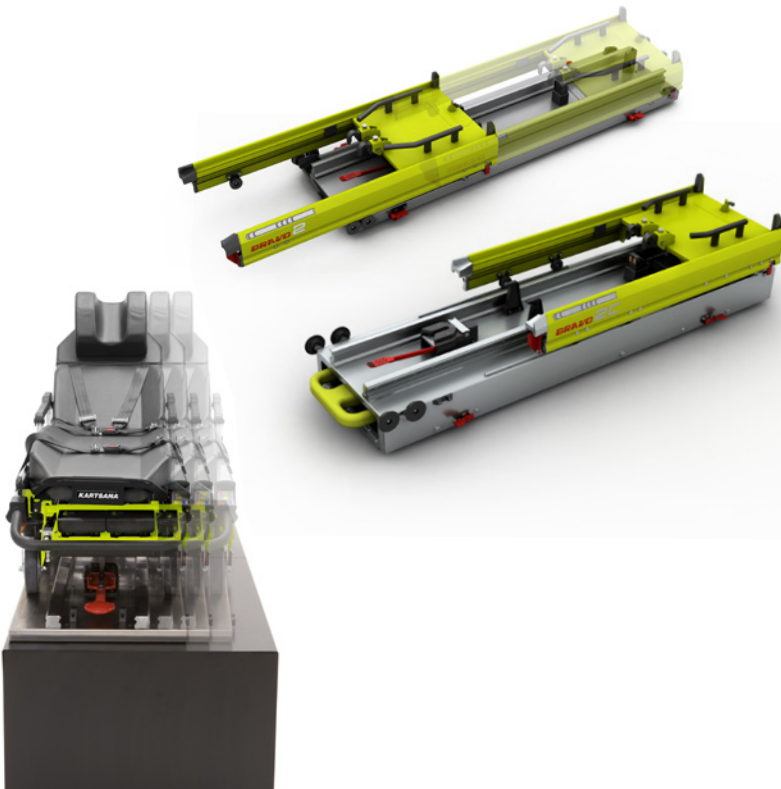

R-1001:

- ▷ BRAVO loading system.
- ▷ Certified 10G.

R-1002A:

- ▷ Telescopic BRAVO loading system with lateral movement.
- ▷ Certified 10G.

R-1002C:

- ▷ BRAVO 2 loading system, with a drawer for storing a backboard stretcher.
- ▷ Certified 10G.

PRODUCT SPECIFICATIONS

	R-1001	R-1002A	R-1002C
H Height (mm)	340	360	460
L Length closed (mm)	2050	2065	2088
L2 Length open (mm)	3090	3130	3145
W Width (mm)	590	632	632
A2 Height rail + stretcher (mm)	509	535	620
Weight (kg)	89	103	117

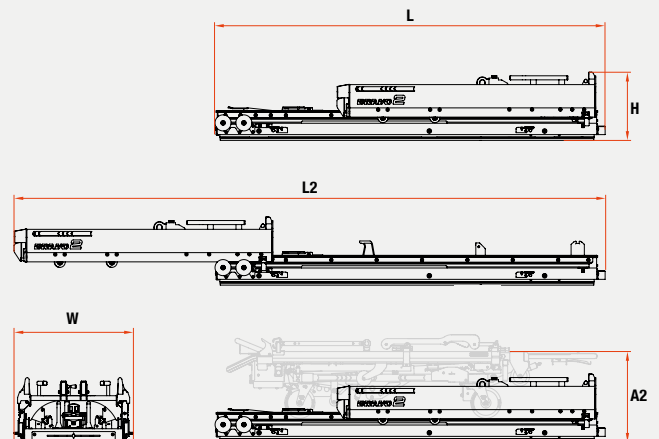

RELATED PRODUCTS



TG-1000 POWER BRAVA



TG-1000 IN



KARTSANA

Life-moving innovation

Narcís Monturiol, 34
08192 - Sant Quirze del Vallès
Barcelona (Spain)

T.: +34 93 715 86 72
info@kartsana.com
www.kartsana.com